



Fitting Instructions

TOWBAR VL34
For VOLVO V40/S40
Mid 1996 -

MATERIALS

A	1	Cross Bar
C	1	Centre Tube with European facing to 94/20/EC A50-1
D	4	M10 x 30 x 1.25mm Fine Pitch Bolts, Lock Washers and Flat Washers (25mm O.D.)
E	1	Right Hand Side Arm
F	1	Left Hand Side Arm
G	2	M10 x 100 x 1.5mm bolts, Nuts, Lock Washers and 4 Flat Washers (20mm O.D.)
G1	2	Bushes (25mm O.D. – 62mm Long)
H	2	Spreader Plates
J	4	M12 x 35 x 1.75mm Bolts, Lock Washers and 4 Nuts
K	2	M10 x 30 x 1.25mm Fine Pitch bolts, Lock Washers and Flat Washers (20mm O.D.)
L	2	M12 x 80 x 1.75mm Bolts and Nyloc Nuts
M	1	M12 x 60 X 1.75mm Bolt, Nyloc Nut and Large Flat Washers (50mm O.D.)
M1	1	Bush (40mm O.D. – 19mm Long)
M2	1	Bush (20mm O.D. – 10mm Long)
N	1	M6 x 20 x 1.0mm Bolt, Lock Washer and Flat Washer
CB	2	M16 x 50mm Coupling Bolts, Nuts, Lock Washers

FITTING

1. Remove bumper (4 tip screws each side, 1 plastic clip on underside, 2 nuts on rear panel, 2 vertical bolts under trim on boot floor). NOTE: On year 2000 model (V40) & (S40) bumper does not need to be removed or cut.
2. Lower rear exhaust silencer (3 hangers) and heat shield (if fitted). Loosely attach Right Hand Side Arm (E) to chassis using 2 Bolts (D). Loosely attach Left Hand Side Arm (F) to chassis using remaining Bolts (D).
3. Ensure all trim and wiring is clear to area above chassis, using Side Arms (E) and (F) as a guide drill up through boot floor for Bolts (G). Loosely attach Spreader Plates (H), inside boot, to Side Arms (E) and (F) using Bolts (G) and Bushes (G1). NOTE: Clear all mastic from seating areas and ensure holes for bumper mounts are aligned. Attach Spreader Plates (H) to bumper mounting brackets using Bolts (K).
4. Loosely attach Cross Bar (A) to Side Arms (E) and (F) using Bolts (J). Attach Cross Bar (A) to towing eye using Bolt (M) and Bushes (M1) and M2).
5. Cut bumper as shown. *NO CUT ON YEAR 2000 MODEL V40 & S40.* Re-fit bumper. Attach Centre Tube (C) to Cross Bar (A) using Bolts (L). Tighten all bolts. Re-fit heat shield using longer Bolt (N). Re-fit exhaust.

Note: This towbar must be used with either a Witter Towball (part number Z1) or Class A50-1 or A50-X towball dimensionally Conforming to A50-1 with a 'D' and 'S' value greater than or equal to that of the towbar.

Please refer to the vehicle specification for the trailer weight and nose limits, which **must be observed**.

Recommended torque settings: M8 - 27Nm, M10 - 53 Nm, M12 - 95 Nm, M14 - 150 Nm, M16 - 214 Nm

SEE ATTACHED DRAWING



Fitting Instructions

TOWBAR VL34
For VOLVO V40/S40
Mid 1996 -

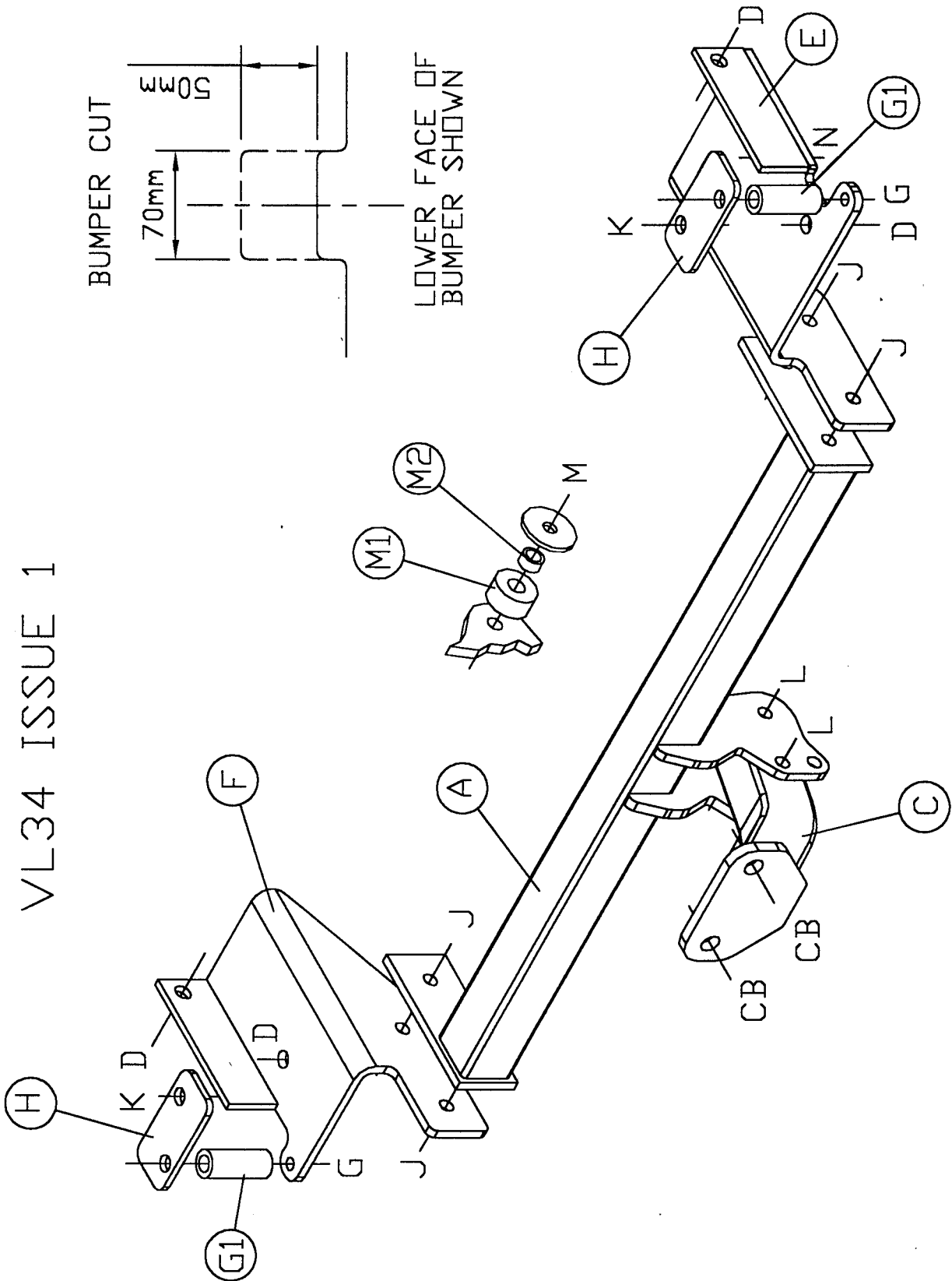

VL34 ISSUE 1