



Fitting Instructions

TOWBAR C29AR
For CITROEN C5 ESTATE

MATERIALS

A	1	Towbar Mainframe with European facing 94/20/EC – A50-1
C	1	Centre Neck
D	2	Bushes (25mm O.D. – 28mm long)
E	1	Left Sidearm
F	1	Right Sidearm
G	1	C Plate
H	4	M12 x 35 x 1.75mm Bolts, Nuts and Lock Washers
J	2	M12 x 80 x 1.75mm Bolts and Nyloc Nuts
K	4	M10 x 40 x 1.5mm Bolts, Lock Washers and Large Flat Washers (30mm O.D)
L	1	M12 x 45 x 1.75mm Bolt, Nut and Lock Washer
M	1	Electrical Plate
CB	2	M16 x 50mm Coupling Bolts, Nuts and Lock Washers

FITTING

1. Remove underskirt (4 screws under rear valance, 1 screw forward of exhaust hanger). Remove exhaust rubber from welded on exhaust hanger (with the aid of WD40).
2. Loosely attach Right Sidearm (F) and Left Sidearm (E) to chassis rails using Bolts (K).
3. Loosely attach Towbar Mainframe (A) and C Plate (G) to Sidearms (E and F) using Bolts (H and L), **tighten all Bolts**. Attach exhaust rubber.
4. Attach Centre Neck (C) to Mainframe (A) using Bolts (J) and Bushes (D), **fully tighten forward Bolt (J) only**. Note: The towball height can be varied by approximately 25mm depending on how far the Mainframe (A) and Centre Neck (C) are pushed upwards when tightening bolts.
5. The underskirt may be left off the vehicle and **returned to the customer**. If so, attach Electrical Plate (M) and **tighten remaining Bolt (J)**.
If the underskirt is refitted, offer up to vehicle to verify the cut positions, and cut as shown below. Fit Electrical Plate (M) and **tighten remaining Bolt (J)**.

Note: This towbar must be used with either a Witter Towball (part number Z1) or Class A50-1 or A50-X towball dimensionally conforming to A50-1 with a 'D' and 'S' value greater than or equal to that of the towbar, also for use with Witter Removable Towball Unit (part number ZR2L004).

Please refer to the vehicle specification for the trailer weight and nose limits, which **must be observed**.



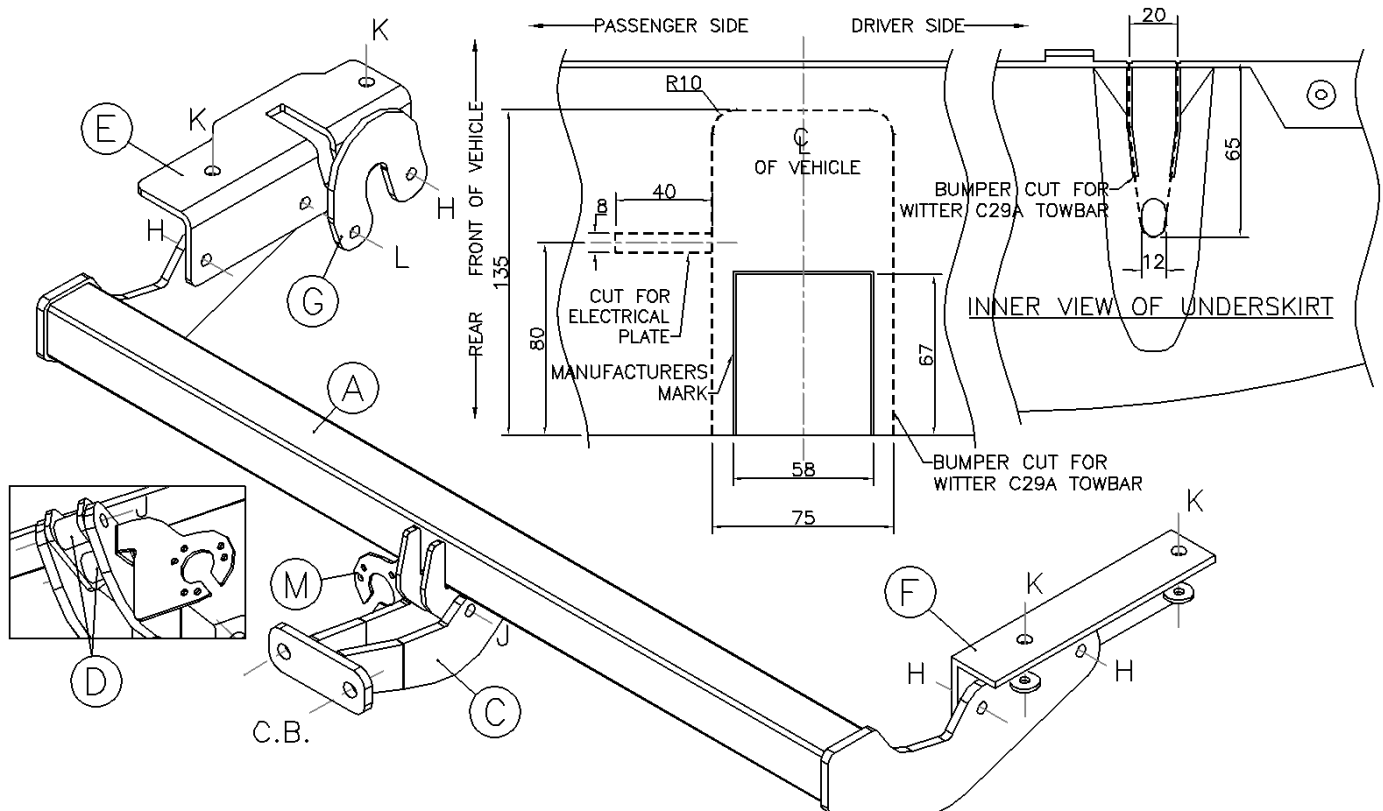

Recommended torque settings: M8 – 27 Nm, M10 - 53 Nm, M12 - 95 Nm, M14 - 150 Nm, M16 - 214 Nm



Fitting Instructions

Detachable Towball System

ZR2

A	Towball Receptor Unit		B	Handle		C	Towball Neck	
P	Safety Chain Plate Nylocs		W	Weather Cover		S	Towball Neck Bag	
						2	M12 x 75mm x 1.75 Bolts +	

FITTING OF TOWBALL RECEPTOR

1. Remove original bolts at (X) and Towbar Centre Part (if fitted).
2. Attach Towball Receptor Unit (A), Safety Chain Plate (P) and original Electrical Plate if removed, to Towbar Centre Plates using replacement Bolts and Nyloc Nuts.
3. Tighten Bolts to 96 Nm.

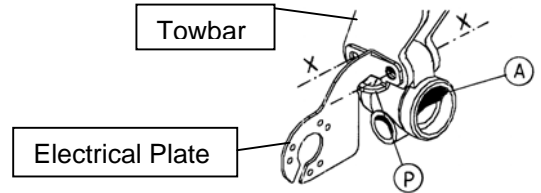

DETACHABLE OPERATION

1. Slide Handle (B) into Towball Receptor Unit (A) and keep orientated as shown.
2. Slide Towball Neck (C) into Towball Receptor Unit (A).
3. Rotate Towball Neck (C) anti-clockwise 180°.
4. Rotate Handle (B) clockwise until Spring Loaded Lock clips into position as shown.

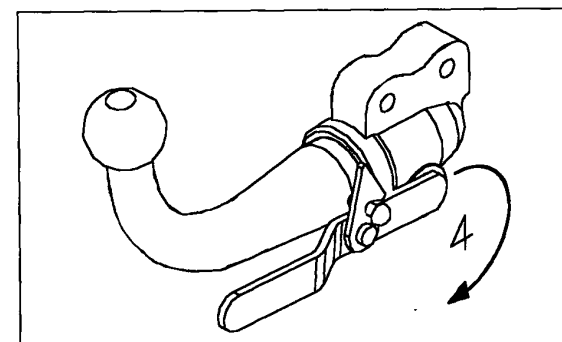
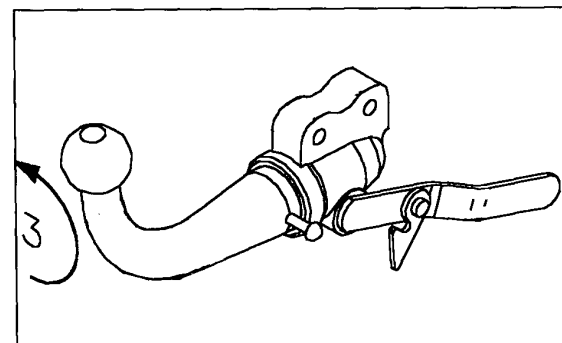
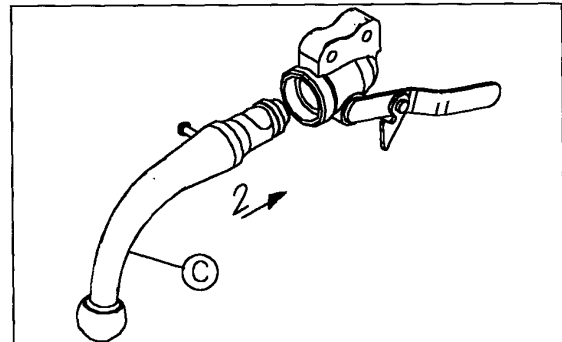
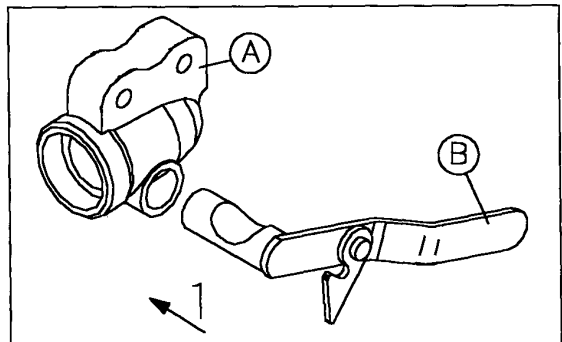

REMOVAL OF TOWBALL

Removal is a reverse of the above procedure. Place Handle (B) and Towball Neck (C) in bag provided. After removing Towball Neck (C) fit Weather Cover (W) to Towball Receptor Unit (A).